

ASSEMBLY INSTRUCTIONS AND PARTS LIST - MODEL P2

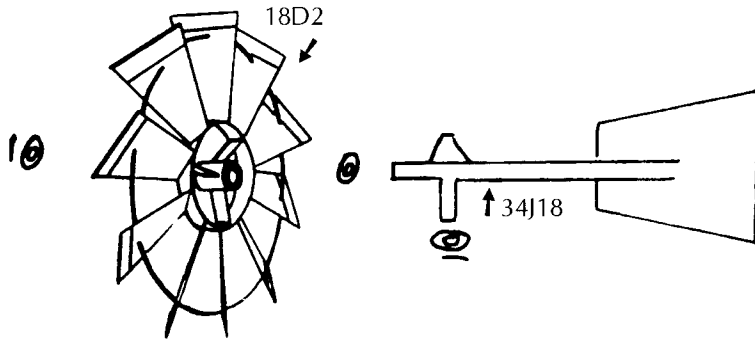

INSTRUCTIONS

Bolt 2-piece corner legs together, with large hole at bottom. Other section goes on top, with holes that are **5 inches apart, up**. Fasten legs to outside of mast head casting. Attach tower braces to outside of corner legs finger tight. (**Note:** Bolts that hold platform should have nuts to the outside). Stand on level flat surface, and tighten all bolts.

Place washer on vertical shaft of tail assembly, and insert shaft into mast head casting. Retain with cotter pin. Slide wheel on horizontal shaft with washer on each side. Retain with cotter pin.

Set tower on level ground and drive ground stakes into four corners at 45°, with open side of "V" angle up. If location is not reasonably protected from severe winds, a more secure mounting on a cement base is recommended.

Grease wheel sparingly with ordinary bearing grease 3 to 4 times per year, or as often as necessary.

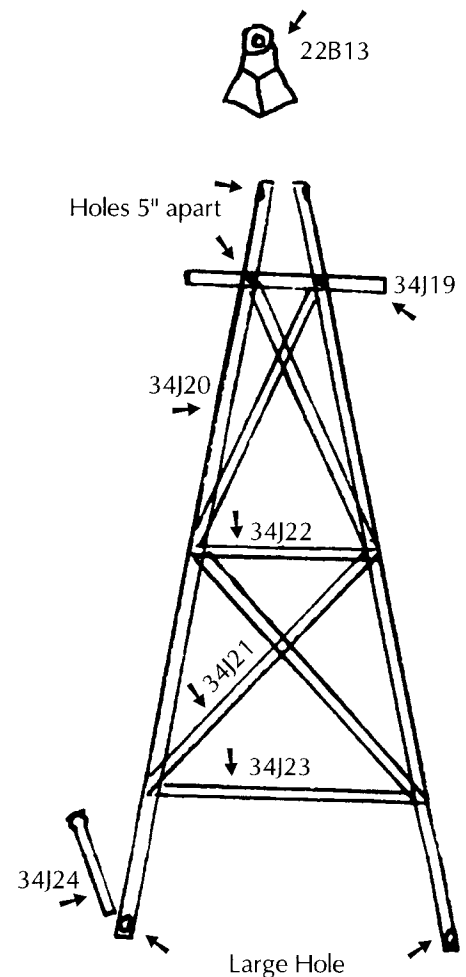

PARTS LIST

18D2	Wheel, with (2) 20B14 bearings	1 ea.
34J18	Tail assembly	1 ea.
22B13	Mast Head Casting	1 ea.
34J19	Platform	1 ea.
34J20	Corner leg (2 piece)	4 ea.
34J21	"X" brace (17" long)	16 ea.
34J22	Center brace (6 1/4" long)	4 ea.
34J23	Lower brace (10" long)	4 ea.
34J24	Ground stakes	4 ea.
18D8	Fastener assortment	1 ea.

CAUTION: INSTALLATION OF MILL SHOULD BE IN A LOCATION WHERE SMALL CHILDREN ARE EITHER RESTRICTED OR SUPERVISED.

AIR ELECTRIC MACHINE COMPANY, INC.
LOHRVILLE, IOWA 51453
 Telephone 712-465-3905